

Sensors and RFID:

The Unbeatable Team for Advanced Error Proofing

Balluff, Inc.
8125 Holton Drive
Florence, KY 41042
Phone: 1-800-543-8390
Fax: (859) 727-4823
www.balluff.com



Error proofing is now an accepted tool for achieving substantial gains in product quality and manufacturing efficiency.

This white paper is intended to provide a general overview of some of the ways sensors can be used to error proof automated production processes. It is by no means the final word on the subject. Instead it can be used as a tool to help start an error proofing discussion or augment an error proofing program.

The Road to Sensor-Driven Error Proofing

Over the past few years, the terms total quality management, lean manufacturing, error proofing, mistake proofing, and Poka Yoke have been used to describe various programs and production techniques that are designed to drive out mistakes in the manufacturing process, while driving down costs, increasing product quality, and increasing overall productivity and profitability.

During the 1970's up until roughly the end of the century, centralized programmable logic controllers were the center of attention when it came to driving improvements in the automation process. Usually the concept of uniformity and repeatability was defined as the name of the game. Back then, software and communication protocols were a common differentiator to measure the effectiveness of an overall automation solution. The key benefits of these systems were to establish higher levels of uniformity and efficiency in the processes themselves. Sensors were an integral part of these systems, but their role was somewhat limited when compared to their expanding role today. They basically communicated to their host PLC that things happened. For example, "The engine block is here. The hole is drilled. +The drill is retracted".

Today the role of sensors has vastly changed. Sensors today do a lot more than send a yes/no or on/off message to a PLC. State of the art production operations don't have an option not to use sensors. When it comes to the production process, PLC's are no longer the center of leverage when it comes to pleasing the customer. Old fashioned quality checks, especially after parts or products are completed, don't cut it. Whether the production process is automatic or semi automatic, sensors teamed with RFID tracking now drive the quality process and are driving the evolution of automation today.

Error proofing, or Poka Yoke, processes made possible by the clever application of sensors and RFID systems are as important as the overall logic and structure of the production processes they work in. They provide the vital links in the automotive parts supply chain and are regarded as the most effective ways of reducing cost and improving manufacturing processes. Sensors today are the primary control components that actually can increase the quality of the product itself. Now sensors can be used to tell the PLC how well things are happening and if the products and parts being made are within spec. Moreover, they can provide this information as an integral part of each step in the manufacturing process, not just as an outmoded quality check.

Meanwhile, RFID tracking, within and between islands of automation, provide a way of tracking not only what has happened, but what has gone right. RFID tracking records where something has gone wrong, and what needs to be done to correct a glitch in an individual component as well as a process step. Manufacturing high-quality parts means much more than building a quality product. The right product must be queued in the correct sequence and delivered at the right time—time after time. This vastly impacts the overall

manufacturing process itself, because RFID not only relates the quality of parts or products being manufactured, but directly to overall system efficiency. This vastly increases the importance of sensors and RFID systems as critical tools to increase the value of a manufacturer to its client.

Sensors: Key to Product Quality

While PLCs have a direct impact on overall process efficiency, sensors have a direct impact on product quality. Industrial sensors, which have long proven their effectiveness in queuing basic automation tasks, are being used increasingly in the error proofing function. Advanced sensor technologies are enabling sensors to compete successfully with advanced active error proofing devices such as vision systems. Sensor-driven error proofing, often in concert with RFID, provides a simple and effective means of ensuring that a part is present and in the correct orientation or position for processing.

Active error proofing addresses common production concerns such as:

- Incorrect part installation (wrong bolt size)
- Color mismatches (wrong trim piece)
- Missing parts (washer not installed)
- Insufficient fastening (torque not adequate)
- Insufficient lubrication (not enough grease)
- Product mislabeling
- Products delivered out of sequence

Using Sensors Effectively

Sensors provide standardized outputs that are either discrete (yes/no) or analog (measurement or position). Integrating active error proofing involves determining the right use of sensors and the level of error proofing required. Generally speaking, for sensors to work correctly, certain conditions have to be present. Parts need to be well fixtured, either contained in a fixture, or able to be brought to an inspection station that can hold the required tolerances. There needs to be a manageable number of inspection points per part so that desired parameters can be verified by a reasonable number of sensors. Finally, the location of the detail on the part in question must remain in a constant position relative to the sensor.

Sensors in Assembly and Automation Applications

Inductive Proximity Sensors

A wide range of sensing technologies are found in assembly and automation disciplines. Inductive proximity sensors are the foot soldiers of the sensor world. Relatively simple discrete (on-off) devices such as inductive proximity sensors determine parts presence, feature detection/confirmation, hole presence/absence, and nesting validation. Inductive proxes are robust, stable in operation, reliable, and accurate. They can stand wide temperature ranges and are in general, one of the easiest sensors to deploy. If the target to be detected is metal, an inductive prox is hard to beat.

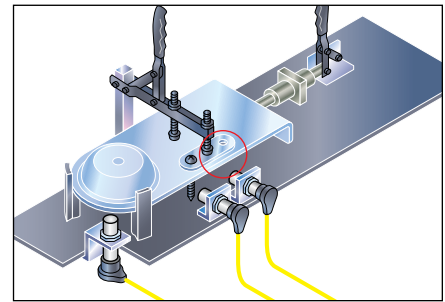

Inductive proximity sensor is used to sense parts presence (screws), plus correct clamping of part before welding.

Photoelectric Sensors

Discrete photoelectric sensors in thru-beam (energized pairs), retro-reflective (used with a dependable target, a reflector) and diffuse reflective (self-contained emitter-receiver pair) modes are all used to detect parts presence

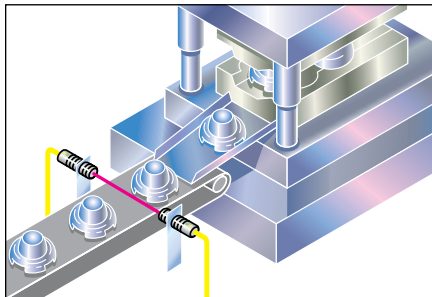

Diffuse photoelectric sensors verify parts count as parts move on conveyor.

when metallic and/or non-metallic components must be detected. The most commonly used photoelectric sensors produce red, infrared or laser emissions. The choice for each is generally determined by the application at hand. Generally speaking, laser sensors provide a more controlled and precise light beam. Red emission photoelectric sensors provide visible and easy to see set up properties, and infrared emissions possess the greatest amount of excess gain, or the ability to sense through industrial hostilities (smoke, oils, mist, steam, etc.). It's all about matching the sensor to the right application.

Analog Sensors

When a simple fixed yes-no response is not enough for successful assembly, an analog sensor can provide the additional data essential for error proofing in flexible manufacturing environments. Analog sensors provide part position information in the form of an analog signal that interfaces directly into the control system, allowing both actual measurements and an infinite variability in yes-no decisions. In addition, some analog sensors offer one or more discrete outputs.

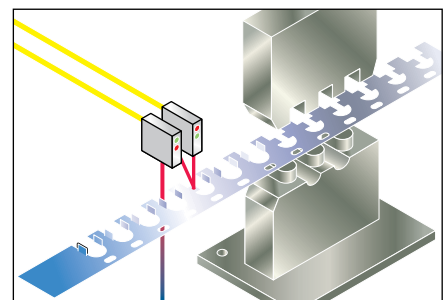

Paired analog photoelectric sensors verify correct bend angle of tabs on this progressive die.

Analog sensors also provide a continuous voltage output for precise gauging, measuring, and positioning of parts in the assembly and automation process. Several models of both inductive and photoelectric technologies offer discrete set points that can be programmed anywhere in the sensing range of the sensor. This feature can help to establish “go-no-go” parameters as well as position feedback in a single sensor device.

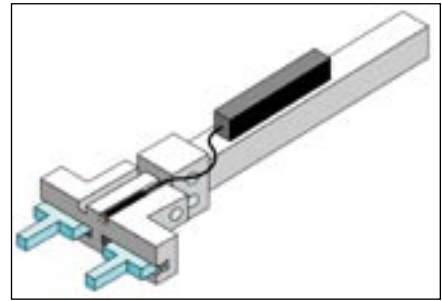

Analog technology is used to exactly track proper jaw position and gripping pressure.

Laser Sensor

Laser-based sensors offer a higher level of precision, ease of use, and cost effectiveness in error proofing applications. Laser sensors detect product details by either using diffuse, diffuse with background suppression techniques, or breaking a beam using thru-beam or retro-reflective techniques. Beam-break versions are reliable, accurate, and capable of long range position detection without regard to target color. Thru-beam sensors can error proof product details either based on part missing or part shape differentiation.

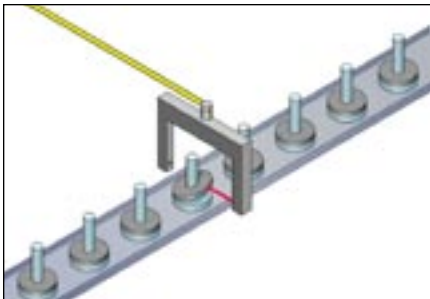

Laser thru-beam sensor spots misassembled washer.

Easily seen laser spots assist operators by highlighting the specific product detail and are especially useful for informing the operator about error locations after detection. The long range capability of lasers allows them to be positioned around operators or moving tooling, enabling more points of detection in smaller areas. In addition, the precision available from laser sensors is often far in excess of what the machine fixturing can provide. The better the machine tolerance, the better the laser performs in that operation.

Color Sensors

When manufacturers need to validate color-matched components, color sensors are used to verify that the right color of component was put on the right device in production. Color sensors come in a wide range of sophistication. On the low cost end, there are cost effective, easy to program sensors available that will detect and hold in three colors or shades of color in memory. These solve 80-90% of the day-to-day color sensing requirements found in manufacturing processes.



Working together, these two color sensors can exactly match and error proof color of two dissimilar floor mat materials.

True color sensors are perfect for highly specialized applications such as color matching and in-line vehicle sequence (ILVS) verification in the automotive industry. In this case, color sensors are tuned to sense the difficult

darker shades typically found in automotive interiors. These color sensors are able to learn three individual colors without the need for external lights or controllers. Setting the sensor is accomplished by teaching the intended color and then assigning a tolerance level to that color setting. Narrow tolerance levels allow detection of small shade differences, while widening the tolerance allows for acceptable shade variations due to color lot inconsistencies. Two decision modes are also available to handle shiny or matte surfaces.

UV Sensors

UV tracing is the most reliable method of error proofing complex assembly tasks—even better than a vision system. There are two steps in the UV tracing process. The first step is to apply the luminescent tracer material

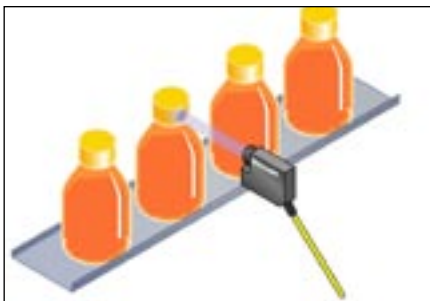

UV photoelectric sensor reads invisible tracer on medicine bottle cap to verify contents.

to the parts in question. The second step is to use a UV sensor to detect the tracer material. When the sensor sees a certain level of luminosity from the tracer, the part has been positively identified.

The advantages of UV sensors include reliability, accommodation of loosely fixtured parts, the use of fiber optic cabling for tight locations, simple teach-in controls, and compatibility with any control system. The benefit is that target materials are invisible to the human eye, inert (no chemical reactions) and have no negative impact on any product aesthetics. Many grease/

lubricants inherently “glow” or react to UV sensors. In fact, many engine test stand and powertrain (engine, transmission, transfer case) manufacturers use UV sensors to detect leaks and overflow to determine fill levels in lubrication tests prior to installation.

Application Knowledge: The Essential Ingredient in Error Proofing

Regardless of the sensor that is deployed, application expertise is the crucial catalyst when it comes to effective operation. In fact, a less capable sensor deployed cleverly is often far more effective than a more powerful sensor poorly applied. Tubular, “flatpack”, and block-style sensors in a wide range of geometric configurations are available to meet specific mechanical and/or electrical application requirements. This is where skilled machine operators, maintenance personnel, and sensor suppliers can make a vast difference in increasing product quality and assembly line efficiency. A close working relationship with your sensor supplier pays dividends here.

Sensor Protection: A Key to Downtime Prevention

A major factor in downtime prevention is the protection of sensors from impact damage, and, in the weld cell environment, slag and heat. Once again, application expertise is the key to long sensor life. Impact causes more sensor wastage than all other factors combined. In fact, the vast majority of all premature sensor failures are caused by systemic or incidental impact.



Impact has destroyed these sensors.

If a sensor is in danger of being hit, there are five basic remedies to the situation:

- Use a more robust sensor
- Use a smaller sensor with the same range
- Use a different type of longer range sensor
- Move the sensor out of the way
- Protect the sensor by using bunker blocks, prox mounts, or other similar strategies

Heat

Heat, especially heat found in weld cells, is a major problem, not just for sensors, but for their associated cables and connectors as well. Hot slag accumulation and elevated ambient temperatures created by welding operations can degrade sensor performance and destroy unprotected connectivity. Weld cells can consume large quantities of sensors and connectivity when they are not applied correctly, or are not protected from the hostile weld environment.

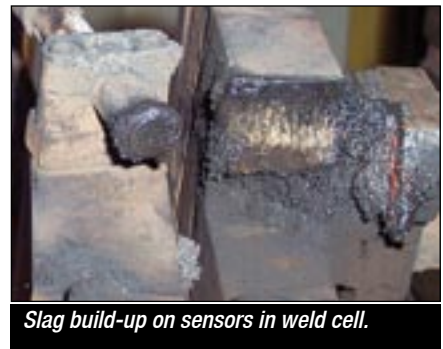

Slag build-up on sensors in weld cell.

(For a complete discussion of these topics, read Balluff's White Paper, "Increasing Sensor Life and Production Productivity" found at www.balluff.com/whitepapers.)

Robotic, Automatic, or Semi-Automatic Weld Cells



Even photoelectric sensors can be protected from harsh weld cell conditions.

As in all manufacturing processes, it's critical to match the sensor to the application. To keep weld cells functioning properly, inductive proximity sensors used for nesting validation must be able to withstand the rigors of loading impact. Coated inductive proximity types must be able to resist accumulation of weld debris (they also facilitate debris removal during scheduled maintenance periods). Photoelectric sensors must have the capacity to sense through smoke and oily film (high excess

gain is imperative) while clamping sensors must be able to handle all of the hostilities listed above plus handle shock and vibration. Everything must be properly bunkered, buried, and sleeved to resist the harshest of conditions and to increase machine up time. The irony is that there are devices available that can achieve these goals, yet they don't always end up in a welding cell or specified during weld cell design and construction. Replacement of unprotected sensors can cost the average weld cell user anywhere between \$6K and \$64K per month, not counting maintenance and machine down time.

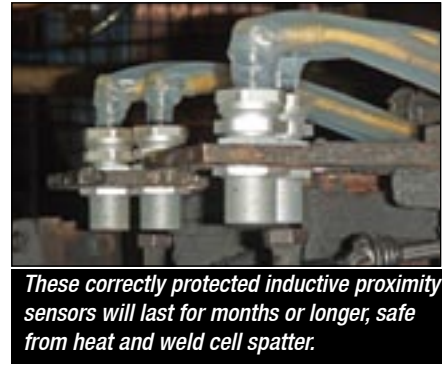

These correctly protected inductive proximity sensors will last for months or longer, safe from heat and weld cell spatter.

Metal Forming Applications

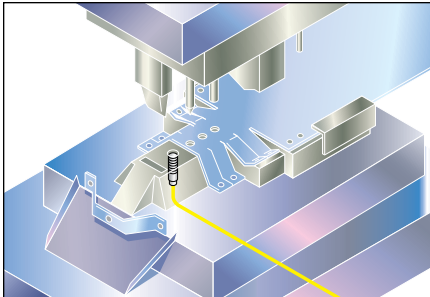

Inductive proximity sensor indicates correct hole positioning prior to each stamping hit.

The same error proofing principles hold true for metal forming as they do for assembly and automation practices, with a few additional objectives. In conjunction to building (stamping) perfect parts for customers with “zero PPM” (bad parts per million), goals are to protect dies from damage (die crash), prevent die lock up, and run production without interruption. The same sensing technologies are used in metal forming as in assembly and automation disciplines, but for different purposes and in different applications.

Discrete sensors are used to monitor stripper position, strip feed, pilot hole detection, and feature detection. They can also be used for slug-out and parts-out sensing in dies for error proofing as well as to prevent double hits. Short range analog sensors can measure bend angles on parts and other critical dimensions or features, and they can measure press parallelism. They are also used for part verification and parts detection on stand-alone error proofing stations. Photoelectric sensors can be integrated to measure precise roll feed, parts out, and slug-out detection.

RFID in metal forming can assure correct die segments are in place. This protects dies from die crashes in large systems before the stamping process occurs. RFID is also used for die identification and tracking, important when a customer can have hundreds of frequently used dies in house.

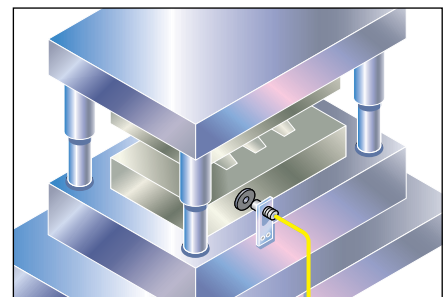

RFID tag verifies correct die and die history prior to stamping process.

RFID in Error Proofing

Flexible manufacturing usually involves various product versions on the same production line. Salient features of each product being manufactured must be identified and tracked because different product versions have unique features to error proof. This is most effectively done by a radio frequency identification (RFID) system that stores build data on a small data carrier affixed permanently to the build pallet.



RFID read/write sensor and electronic tag error proofs automatic tool selection system.

Sensor-based RFID systems have proven especially useful in machining operations where data is included on pallets that move into and out of machining stations. Before assembly begins, the data carrier is loaded with the build information that will instruct all downstream processes as to the exact part version being manufactured. Correct assembly is verified by comparing the build information to what the error proofing sensors detect. Build information can be kept decentralized on each build pallet, held centrally in the control system, or act directly without intervention from the control system. These differences have a direct impact on the communication method required between the control system and the data carriers.

When build information is maintained and referenced centrally in the control system, a simple and economical parallel, read-only interface can be used. This 8-bit interface connects directly to inputs on the control system, significantly reducing integration time. The control system established a virtual build sheet by equating the pallet number to a list of build sheets resident in the control system.

Tracking Build Information/Pallet Identification



RFID sensor correctly reads build information from electronic tag through pool of cutting fluid.

Flexible manufacturing requires the ability to construct various product versions on the same line. Because various product versions have unique features to error proof, the exact version being manufactured must be known.

These ID systems are all matched to the level of complexity required for the application at hand. They can be a simple “read-only”, 8-bit parallel system or a “read-write” type. The build information is written to the data carrier before assembly begins. The assembly system reads the build information at each station to determine what assembly and

error-proofing operation is required. Alternatively, the actual test results can be loaded into the data carrier for subsequent archiving. These systems can read and write data using many standard protocols including ProfiBus, DeviceNet, and ethernet.

Sensors and RFID Team up in the Rework Area

Sensors and RFID technology are also teaming up to minimize errors in the rework process. RFID tags located either on the assembly or the pallet, control exactly what should be done and what has been done within each automation island. When a problem sub-assembly reaches the rework area, the RFID tag identifies the rework that needs to be done, which then triggers the relevant sensors in the area (perhaps located on a torque wrench) using spacial positioning software. This means that the tooling only goes to the correct place in the correct sequence so that the correct repair procedure is the only possible action that can be taken.

In this case, the human operator becomes the actuator, driven by the software informed by the RFID tag and controlled by the sensors.

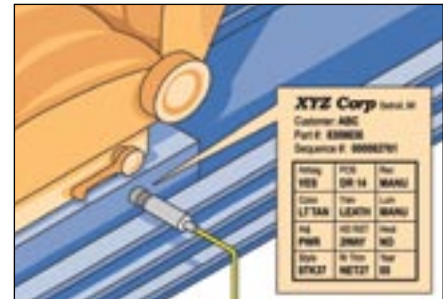

Total build history is read and updated by RFID Pallet ID System.

What's Next in Sensing: Evolution at the Sensor/Vision Interface

As discussed, most discrete sensor-driven error proofing works best when a manufactured part can be automatically positioned for inspection. This must be done exactly the same way so that sensors can be aimed at a specific aspect of a part to verify the manufacturing step was done correctly, or reject the part. Vision-based inspection typically calls for far more expensive equipment to mimic the old fashioned in-line or final inspection method in an automated way. On the other hand, vision methodology has the advantages of being able to inspect parts in various attitudes relative to the camera and inspect more than one attribute simultaneously, such as appearance, presence/absence, dimensional and positioning.

Sensor suppliers are now providing more sophisticated sensors and application techniques advancing up the curve towards vision solutions. Meanwhile vision providers are trying to expand down the curve towards the discrete sensor world. But instead of a crash of technologies, a new layer of technology is evolving that combines the best from both technologies. Now a user with little vision system expertise can apply higher level sensing at a lower cost point, allowing these new optical sensors to be applied more readily in a true error proofing scheme.

Simplified Vision Technology

These new vision-based optical sensor products bridge the gap by providing a simple, practical, and cost effective way to error proof production. They do this by simultaneously checking several aspects of the product with a single device that uses a simple configuration interface that can be learned and used quickly by in-house staff. New optical sensors with a simplified configuration and multiple inspection/measurement tools drive multiple sensing options to provide more information than a single function “smart camera” or a standard discrete sensor. At the same time, they avoid the traps of complex vision systems in cost, complexity, and needed expertise for achieving reliable error proofing.

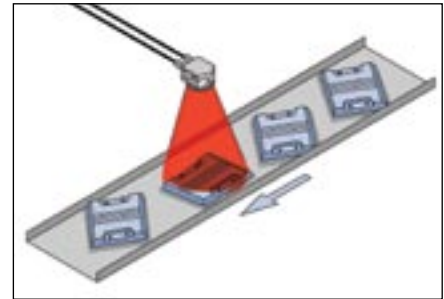

In many applications, vision sensors can do the job more efficiently and less expensively than arrays of multiple sensors.

This new type of vision based sensor is used more like a smart sensor than a vision system. Just like a sensor, it is configured to look for certain attributes of a part or product to make sure specific aspects of the product are present, the part is configured correctly and even verify positioning. But unlike a discrete sensor, the optical sensor does not need the part to be presented exactly the same way for each inspection, thus reducing fixturing costs. And unlike a discrete sensor, it can check for multiple characteristics at the same time, thus justifying its cost with a higher ROI sooner by taking the place of several sensors, each of which can only check on one thing. As apposed to using a more traditional sensing array, these optical sensors can also significantly reduce the complexity and cost of error proofing while improving the reliability. This opens up a whole new world of error proofing that was not available before for reducing planned down time, making easier line changeovers and better accommodating flexible or “build to suit” manufacturing.

(For more information on Vision Technology, read Balluff’s White Paper, “Where Vision Meets Sensors” found at www.balluff.com/whitepapers.)

The Bottom Line:

If your company is not using some of these techniques, you are in danger of being left behind in the race for manufacturing sector survival. Balluff is eager to help. Contact us to help you get started, or to help solve a specific error proofing problem. Remember, with error proofing, the solution is the sensor.

For more White Papers from Balluff, visit
www.balluff.com/whitepapers



www.balluff.com

USA

Balluff Inc.
8125 Holton Drive
Florence, KY 41042
Phone: (859) 727-2200
Toll-free: 1-800-543-8390
Fax: (859) 727-4823
E-Mail: balluff@balluff.com

Canada

Balluff Canada, Inc.
2840 Argentia Road, Unit #2
Mississauga, Ontario L5N 8G4
Phone: (905) 816-1494
Toll-free: 1-800-927-9654
Fax: (905) 816-1411
E-Mail: balluff.canada@balluff.ca

Mexico

Balluff de Mexico S.A. de C.V.
Prol. Av. Luis M. Vega #109
Col. Ampliacion Cimataro
Queretaro, QRO 76030
Phone: (+52 442) 212-4882, 224-3583, 224-3171
Fax: (+52 442) 214-0536
E-Mail: balluff.mexico@balluff.com