

Solutions for Automation, Assembly & Packaging

TL SERIES

PRECISION LINK TRANSFER CONVEYOR

TL Sizes: 25-50-75-100-105-150-200-250

TSL Sizes: 50

TXL Sizes: 75-100-150

Index Stroke Distance: 25 to 600 mm or flexible positioning via servo motor.

Lengths up to: 9100 mm (longer lengths available upon request)

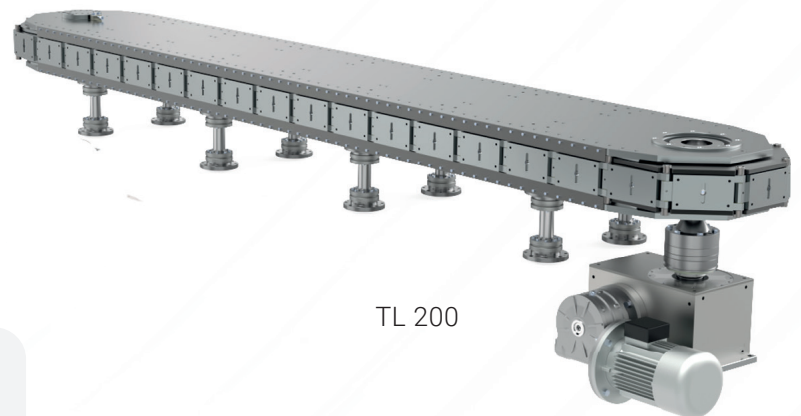

TL 200

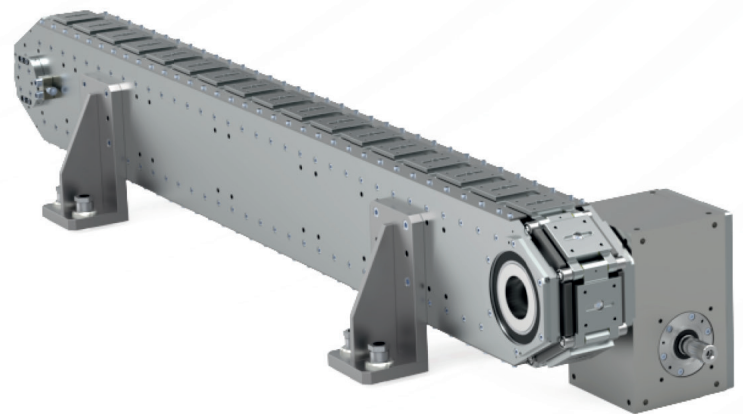

TL 100

SPECIFICATIONS

- Fixed indexing or flexible positioning via servo drive.
- Modular design for flexible platform configurations and ease of customization.
- Carousel or Over/Under mounting styles.
- Clean Room certified for Medical, Pharma & Cosmetic applications.
- Rigid nickel plated links.
- Chordal compensation take up cams to maintain link tension.
- Highest station to station accuracy.
- Custom options available include: machine bases, line shafts & synchronized parts handlers.